



CLEANROOM PASS BOX LIFT W/CONVEYOR

Product Description

The best way to minimize contamination is to keep unnecessary people out of the controlled environment. A pass-box significantly minimized such human traffic and contamination by providing a better and safer way to transfer materials, equipment, and documents into and out from the cleanroom.

The Pass Box Lift with Conveyor offers an effective and efficient way to transfer materials into and out from the clean rooms. The unit's conveyor system is activated automatically once the material is loaded onto the conveyor and the user activates the system by pushing the start button.



Cleanroom Side



Dirty Room Side

Features

- Powder coated EG Steel or SUS 304 Main Body
- Automated Conveyor with sensors and stoppers
- Integrated Lift within Pass Box
- Auto-Shutter Doors
- PLC Control

Applications

An ideal choice for materials personnel to pass into raised cleanroom areas without sacrificing cleanliness for convenience.

CLEANROOM PASS BOX LIFT W/CONVEYOR

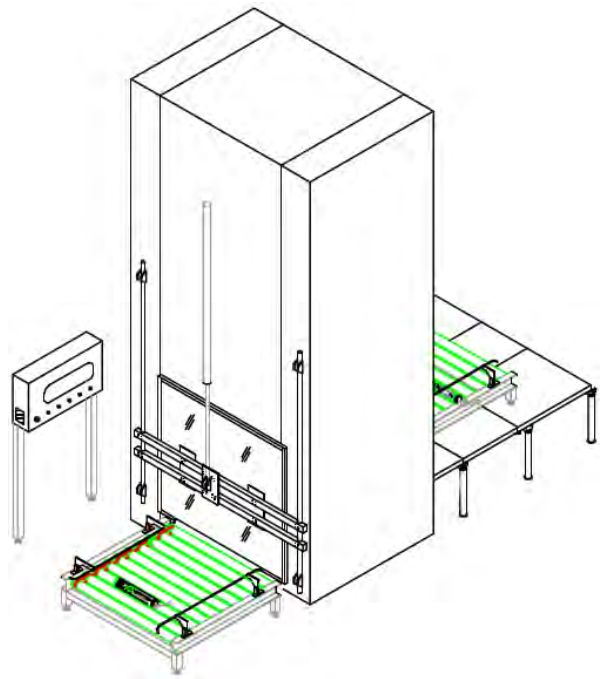

Standard Technical Specifications

| | |
|---------------------|------------------------------------|
| Model | P2M-PBL-Roller |
| External Dimensions | 1340 W x 1100 D x 2900 H |
| Internal Dimensions | 720 W x 1100 D x 800 H |
| Structure | Powder-coated EG Steel or SUS 304 |
| Roller Drive | Series EC100 (2 grooves) SUS-plate |
| Free Roller | Series 1700 (2 grooves) SUS-plate |
| Lift | Air-cylinder system x 2 sets |
| Door | Shutter-door air-cylinder system |

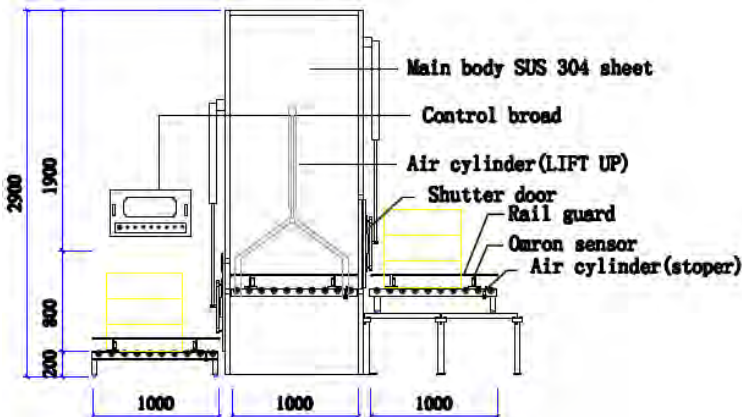

P2M (THAILAND) CO. LTD
 75/8 Moo. 11, T.Klong Nueng, A. Klong Luang,
 Pathumthani 12120. Thailand
 Tel. (66) 0 2520 3976-9 Fax. (66) 0 2520 3998
 Email : sales@p2mgroup.com.
 Website : www.p2mgroup.com

